



## Vechline Solar Panels DBC

**80w – 105w – 130w – 155w – 195w – 235w – 280w**



1. General
2. Way of working
3. Configuration and Technologic parameter
4. Installation and Operation
5. Fixing
6. Storage and carriage
7. Maintenance
8. Warranty

## 1 General

PV Solar electric system is a kind of solar cell array, composed with all types of solar modules according to system load power (load current and voltage), iron bracket, solar control device (include controller and inverter), storage battery and cable etc (see chart 1). It can provide DC electric output and AC electric output after inversed.

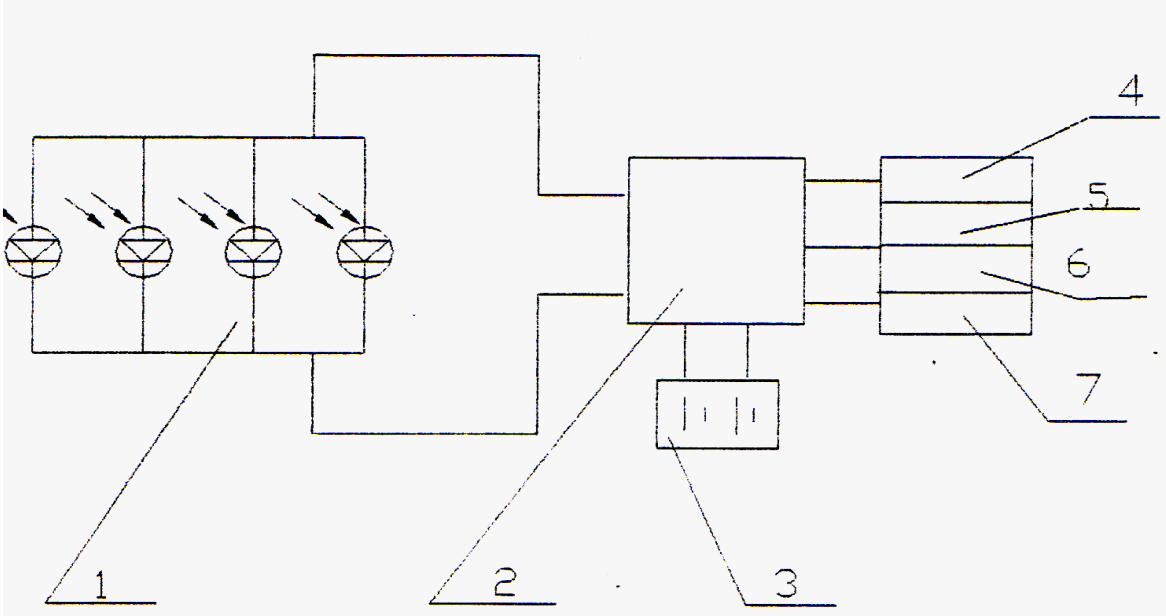

1. Solar modules& bracket
- 2.Solar control device
3. Battery
4. 5. 6. 7. load Utilization

**Chart 1. PV Solar electric system**

## 2 Way of working

Solar modules are a semi-conductor product, which can transform sunlight to electric power. It is also a energy source clear re-new which doesn't need water neither oil and gas but only sunlight. It can form all types of solar modules after some process: the solar arrays are installed on the iron bracket in series or parallels type according different electric current needed by load. Only in a sunny day, solar arrays can transform sunlight to electric power and provide this power to output load. During night or rainy day, output power is very low because brightness is very weak. In order to solve this problem, the solar arrays must connect with storage battery. In case of a higher brightness, the solar arrays not only can provide electric power for output load but also can charge power for storage battery. When the brightness is weak, the storage battery can provide electric power for output load, including panels flow. The integrated PV Solar electric system also needs anti-reverse diode, to avoid a discharge of the battery during the night: this diode is usually included in the charge controler.

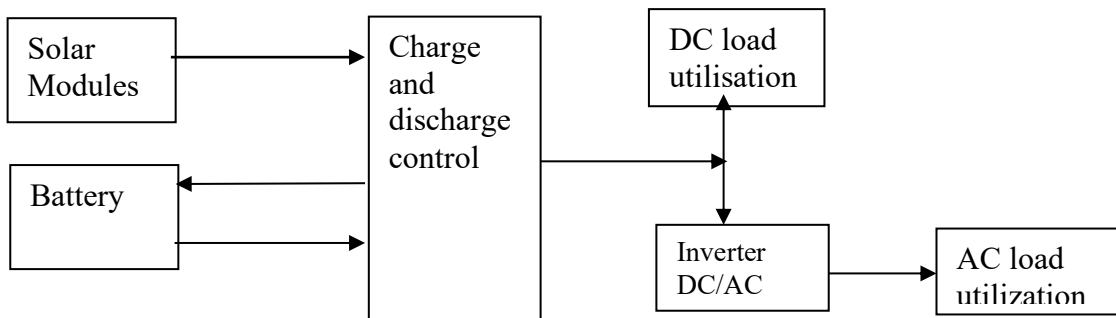

**Chart 2. PV Solar electric system instruction**

### 3 Configuration and Technologic parameter

Solar modules have a high resistance to ultraviolet radiation, a long life and a good reliability.

Solar module specification and Technologic parameter :

Test condition: AM: 1.5  $E_e=100\text{mw/cm}^2$   $T=25\pm 2^\circ\text{C}$

Modèle	Wp (nominal)	Vmp (V)	Imp (I)	Dimensions (mm) Longueur x largeur x hauteur	Poids brut (Kg)
Vechline DP 80w	80 +/-5%	18,5	4,33	1135 × 405 × 58	7,0
Vechline DP 105w	105 +/-5%	18,5	5,68	1135 × 530 × 58	8,0
Vechline DP 130w	130 +/-5%	18,5	7,03	1135 × 658 × 58	9,5
Vechline DP 155w	155 +/-5%	27,7	5,6	1642 × 530 × 58	11,0
Vechline DP 195w	195 +/-5%	27,75	7,03	1642 × 658 × 58	13,0
Vechline DP 235w	235 +/-5%	27,75	8,47	1642 × 785 × 58	14,5
Vechline DP 280w	280 +/-5%	28,0	10,0	1642 × 912 × 58	16,5

### 4 Installation and Operation

**In the she solar module are included two bypass diodes, which should not be removed. The bypass diodes can't replace the anti-reverse diode.**

4.1 Only the skilled fitter can work on these modules. The system involves electricity, and can be dangerous.

4.2 During installation, please take care of glass, please avoid hitting or heavy weight.

4.3 The solar modules' surface receiving the sunlight will be toward south.

4.4 Solar modules, installation position manner (in series, in parallel) on bracket must be according to drawing. The tilt angle should be adjusted according to latitude.

Chart 3

Vechline DP80w

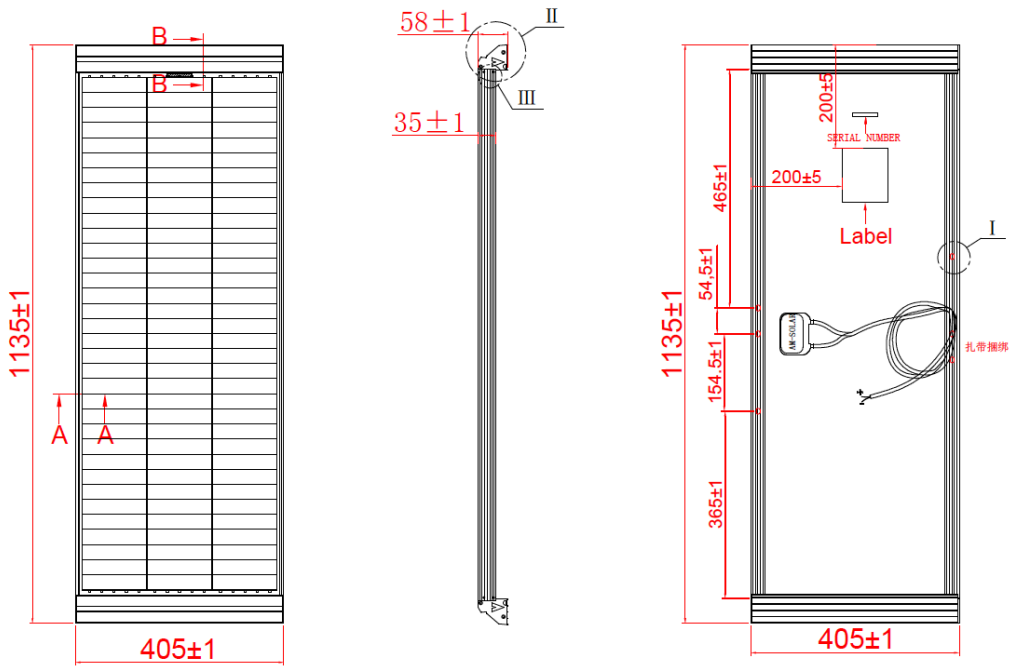

Vechline DP 105w

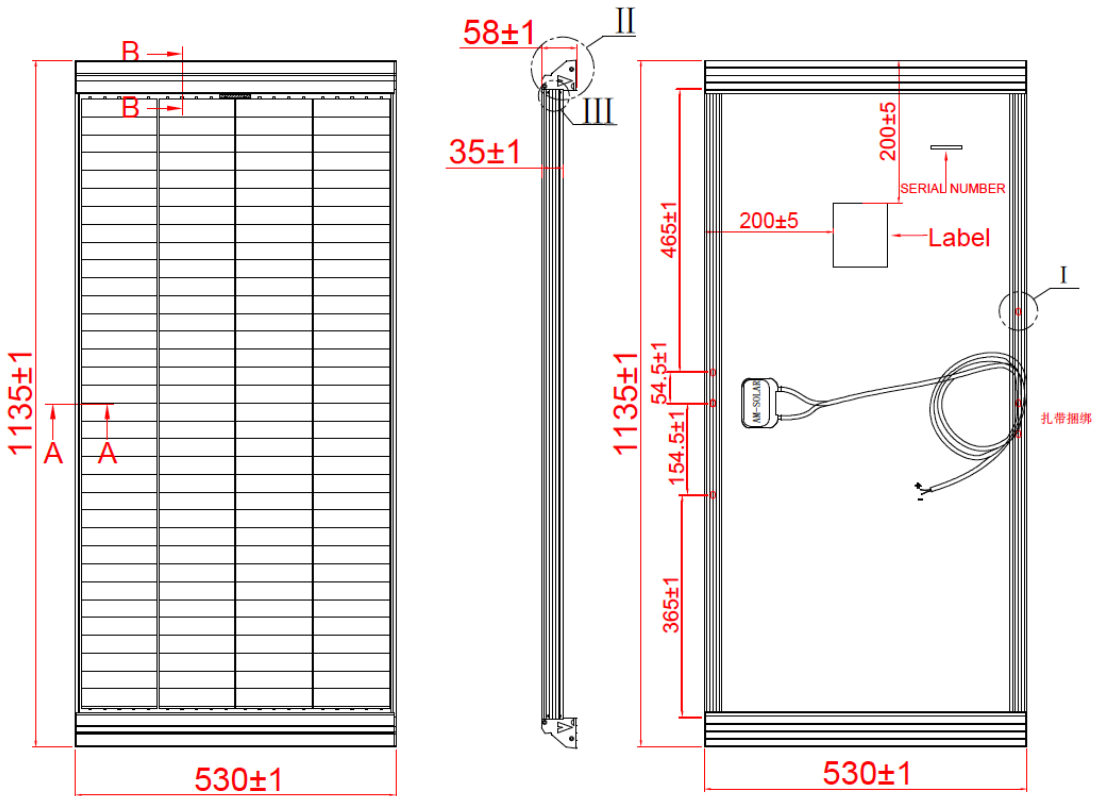

Vechline DP 135w

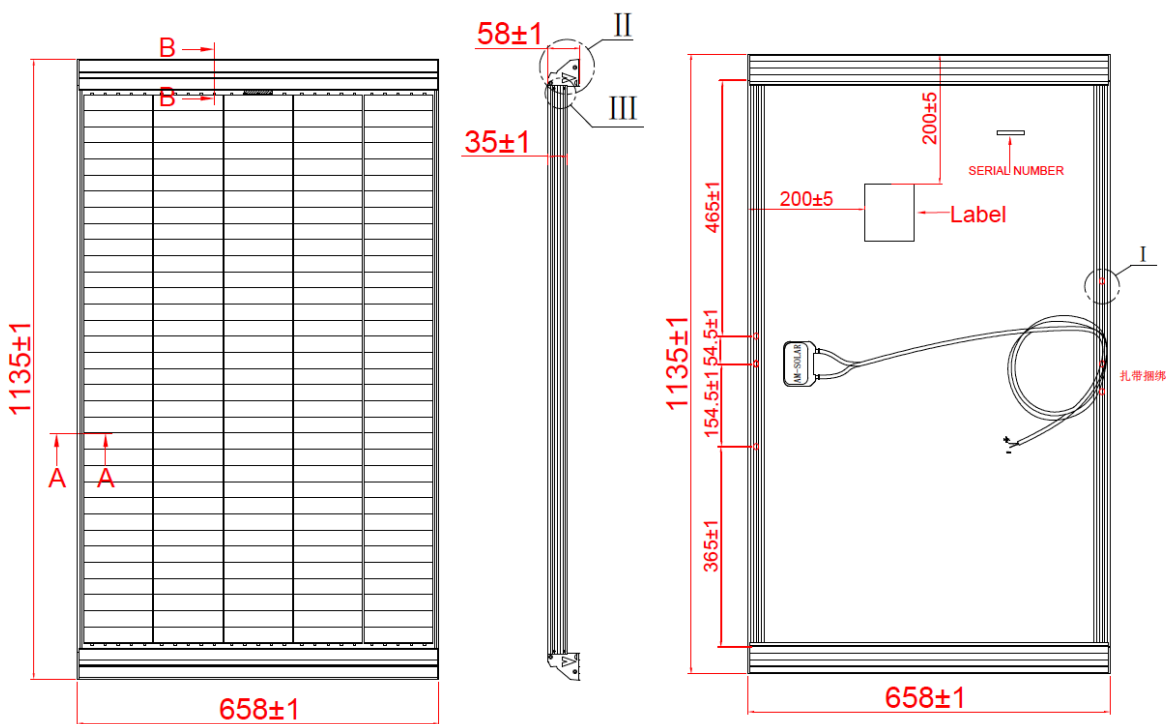

Vechline DP155w

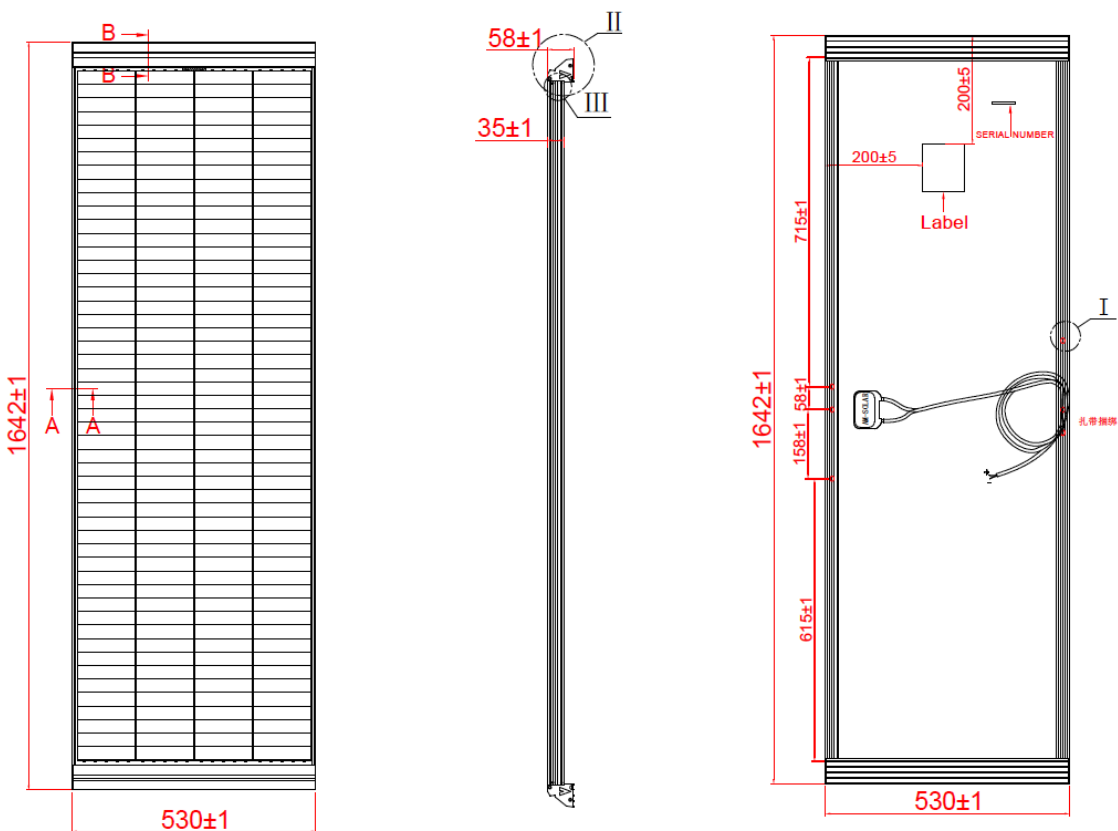

Vechline DP 195w

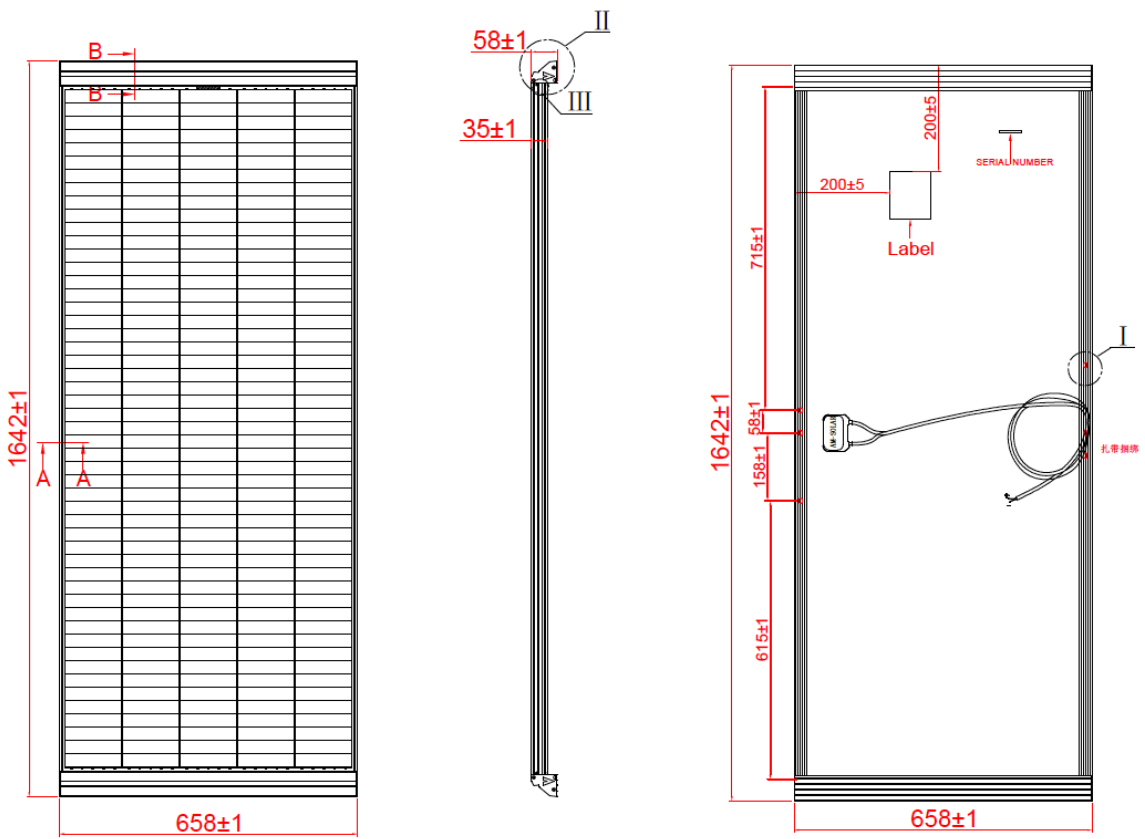

Vechline DP 235w

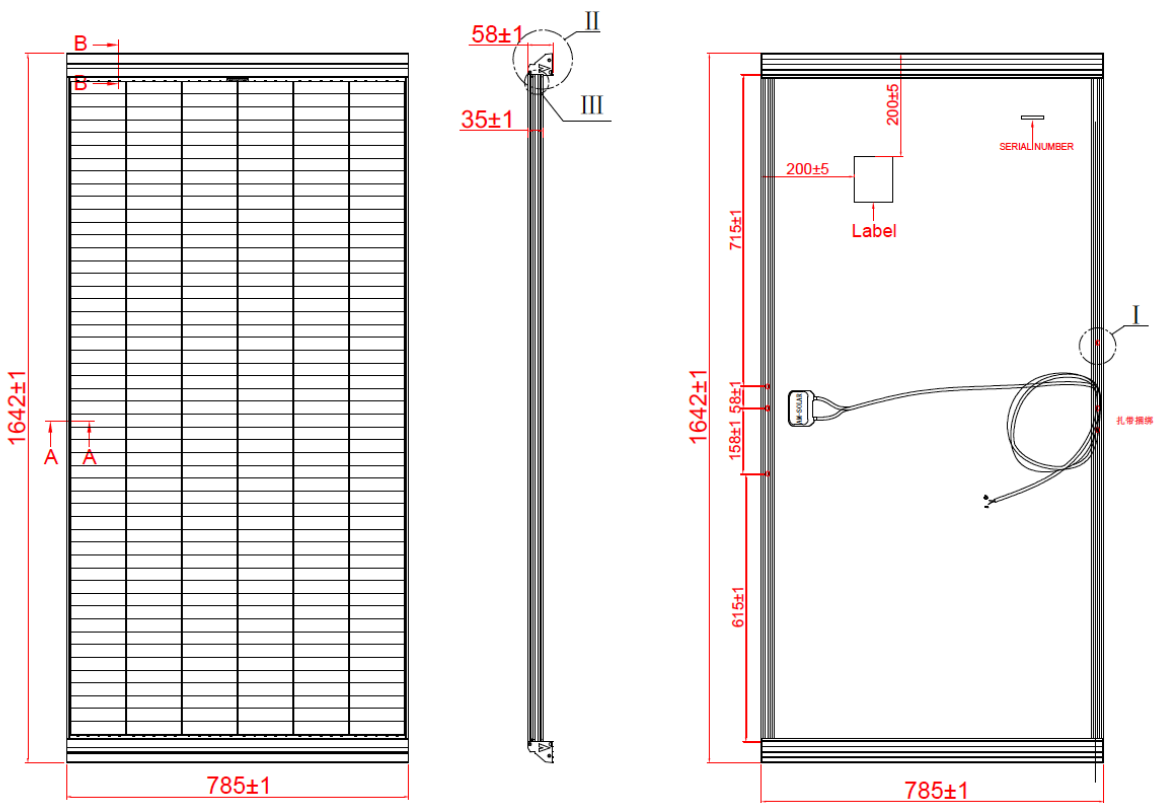

## Vechline DP 280w

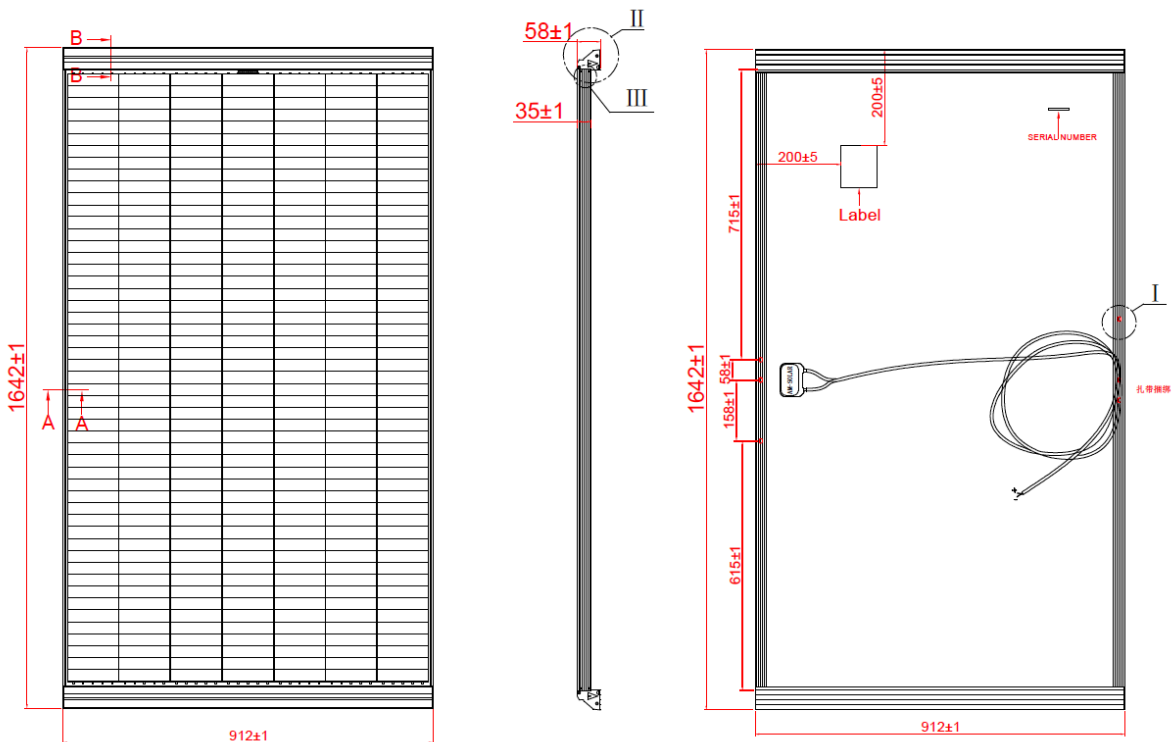

4.5 The polarities of the output connectors must be respected . The by-pass diodes are included in the connection box and are pre-cabled. They must not be disconnected.

4.6 The module frame is made of anodized aluminum, and therefore corrosion can occur if the module is subject to salted water environment in contact with another type of metal. If required, PVC can be placed between the solar module frame and support structure to prevent this type of corrosion.

4.7 The solar module frame must be fixed to the roof using the glue included in the kit.

4.8 When the Solar modules are connected, the surface of the modules must be covered by something like black cloth, cotton blanket etc.

4.9 Before connect solar array to the controller, storage battery must be first connected to the controller, then load and module array can be connected to the proper terminal. Be aware of Battery electrode connection to protect the controller.

4.10 The user should check the system regularly, and make sure system is normally working.

## 5 Fixing

5.1 The solar modules are designed to be glued on a clean and smooth surface using the glue supplied in the kit.

5.2 The gluing must done at a temperature between 15°C and 30°C in a clean and dry room (no rain, no dust...). If not, the efficiency of the gluing won't be satisfactory.

5.3 Clean carefully the surfaces to be glued, wipe them with a dry and clean duster and let dry. The humidity and the dirt do not allow a correct gluing.

5.4 Apply the cleaner supplied in the kit to the surfaces destined to be glued. To do so, break the phial included in the applicator and apply it to the corresponding surfaces. Let dry a few minutes.

5.5 Apply the glue to excess in the grooves of the module supports. The volume of glue must be bigger than the volume of the grooves.

5.6 Apply the module on the roof at the selected place, press evenly and with restraint. Control the

supports are in contact.

5.7 Remove the excess of glue with a dry and clean duster.

5.8 Let dry at least 4 hours or more if the temperature is below 20°C

## **6 Storage and carriage**

6.1 The solar modules should be stored in dry environment, and not in a corrosive environment.

6.2 Load and unload modules must be carried very carefully.

## **7 Maintenance**

Solar modules are designed according to the rule of long life and free of maintenance. Usually, normal rainfall and wind is sufficient to keep the module glass clean. If necessary, you can clean the glass with a soft cloth using mild detergent and 50% of water. Be careful ! Don't cut the protection film at the back of solar modules.

## **8 Warranty duration:**

- 2 years for the charge controller
- 1 year for the module assembling
- 10 years for the power (90% of the nominal power).